

S1D13781 Display Controller

S5U13781P00C100 Evaluation Board User Manual

Document Number: X94A-G-001-01.4

Evaluation Board/Kit and Development Tool Important Notice

1. This evaluation board/kit or development tool is designed for use for engineering evaluation, demonstration, or development purposes only. Do not use it for other purposes. It is not intended to meet the requirements of design for finished products.
2. This evaluation board/kit or development tool is intended for use by an electronics engineer and is not a consumer product. The user should use it properly and in a safe manner. Seiko Epson does not assume any responsibility or liability of any kind of damage and/or fire caused by the use of it. The user should cease to use it when any abnormal issue occurs even during proper and safe use.
3. The part used for this evaluation board/kit or development tool may be changed without any notice.

NOTICE

No part of this material may be reproduced or duplicated in any form or by any means without the written permission of Seiko Epson. Seiko Epson reserves the right to make changes to this material without notice. Seiko Epson does not assume any liability of any kind arising out of any inaccuracies contained in this material or due to its application or use in any product or circuit and, further, there is no representation that this material is applicable to products requiring high level reliability, such as, medical products. Moreover, no license to any intellectual property rights is granted by implication or otherwise, and there is no representation or warranty that anything made in accordance with this material will be free from any patent or copyright infringement of a third party. When exporting the products or technology described in this material, you should comply with the applicable export control laws and regulations and follow the procedures required by such laws and regulations. You are requested not to use, to resell, to export and/or to otherwise dispose of the products (and any technical information furnished, if any) for the development and/or manufacture of weapon of mass destruction or for other military purposes.

All brands or product names mentioned herein are trademarks and/or registered trademarks of their respective companies.

©SEIKO EPSON CORPORATION 2009-2018. All rights reserved.

Table of Contents

Chapter 1 Introduction	5
Chapter 2 Features	6
Chapter 3 Installation and Configuration	7
3.1 CNF[2:0] Configuration	7
3.2 Configuration Switches	8
3.3 Configuration Jumpers	9
3.4 Zero Ohm Resistor Configuration	11
3.5 Power Requirements	11
3.5.1 IOVDD, COREVDD, PLLVDD	11
3.5.2 3.3V	11
3.5.3 Backlight Power Supply for LCD Panel	11
3.6 LED Status Indicators	13
Chapter 4 Connectors	14
4.1 CN1, CN2 Panel Interface Connector	14
4.2 CN3, CN4 Host Bus Interface Connector	14
4.3 P1, P2 Connecting to the Epson S5U13U00P00C100 USB Adapter Board	15
Chapter 5 Technical Description	17
5.1 Current Measurement	17
5.2 Oscillator Support for CLKI input	17
5.3 Hardware Reset	18
Chapter 6 Parts List	19
Chapter 7 Schematic Diagrams	22
Chapter 8 Board Layout	27
Chapter 9 Change Record	29
Chapter 10 Sales and Technical Support	31

Chapter 1 Introduction

This manual describes the setup and operation of the S5U13781P00C100 Evaluation Board. The evaluation board is designed as an evaluation platform for the S1D13781 Display Controller.

The S5U13781P00C100 evaluation board can be used with many native platforms via the host connector which provides the appropriate signals to support a variety of CPUs. The S5U13781P00C100 evaluation board can also connect to the S5U13U00P00C100 USB Adapter board so that it can be used with a laptop or desktop computer, via USB 2.0.

This user manual is updated as appropriate. Please check the Epson Research and Development Website at vdc.epson.com for the latest revision of this document before beginning any development.

We appreciate your comments on our documentation. Please contact us via email at vdc-documentation@ea.epson.com.

Chapter 2 Features

The S5U13781P00C100 Evaluation Board includes the following features:

- QFP 100pin S1D13781F00A100 Display Controller
- Headers for connection to various Host Bus Interfaces including termination switching for un-used pins
- Headers for connection to the S5U13U00P00C100 USB Adapter board

Note

The SPI interface is not available when the S5U13781P00C100 evaluation board is used with the S5U13U00P00C100 USB adapter board.

- Headers for connection to various LCD panels
- On-board 24MHz crystal (EPSON SG-210 or RIVER ELETEC FCXO-05)
- 14-pin DIP socket (if an oscillator for CLKI input is required)
- 5.0V input power
- On-board voltage regulator with 1.5V output, for CORE/PLLVDD
- On-board voltage regulator with adjustable 1.5~3.8V output, for IOVDD
- On-board voltage regulator with 3.3V output, for on-board OSC
- On-board voltage regulator with adjustable 12~30V output, 350~100mA max., to provide power for LED back-light of LCD panels.

Chapter 3 Installation and Configuration

The S5U13781P00C100 evaluation board incorporates a DIP switch, jumpers, and 0 ohm resistors which allow it to be used with a variety of different configurations.

3.1 CNF[2:0] Configuration

The S1D13781 has 3 configuration inputs CNF[2:0], which are used to configure the S1D13781 host interface type through DIP switch SW1. Depending on the CNF[2:0] setting, some host interface pins will not be used. Those pins should be terminated by SW2 and SW3.

Table 3-1: Host Interface Pin Mapping

S1D13781 Pin Name	Direct 16-bit Mode 1	Direct 16-bit Mode 2	Indirect 16-bit Mode 1	Indirect 16-bit Mode 2	Direct 8-bit	Indirect 8-bit	SPI (note 4)
CNF[2:0]	000	001	010	011	100	101	111
CS#	CS#	CS#	CS#	CS#	CS#	CS#	CS#
WR#	WR#	RDU#	WR#	RDU#	WR#	WR#	SCK
RD#	RD#	RDL#	RD#	RDL#	RD#	RD#	SW2-3=On
UB#	UB#	WRU#	UB#	WRU#	SW2-1=On	SW2-1=On	SW2-1=On
LB#	LB#	WRL#	LB#	WRL#	SW2-2=On	SW2-2=On	SW2-2=On
AB0	TE (JP108 2-3)	TE (JP108 2-3)	TE (JP108 2-3)	TE (JP108 2-3)	AB0	TE (JP108 2-3)	TE (JP108 2-3)
AB1	AB1	AB1	P/C#	P/C#	AB1	P/C#	Low
AB[18:2]	AB[18:2]	AB[18:2]	Low	Low	AB[18:2]	Low	Low
DB0	DB0	DB0	DB0	DB0	DB0	DB0	SI
DB1	DB1	DB1	DB1	DB1	DB1	DB1	SO
DB[7:2]	DB[7:2]	DB[7:2]	DB[7:2]	DB[7:2]	DB[7:2]	DB[7:2]	SW2-5~10=On
DB8	DB8	DB8	DB8	DB8	TE (JP109 2-3)	SW3-1=On	SW3-1=On
DB[15:9]	DB[15:9]	DB[15:9]	DB[15:9]	DB[15:9]	SW3-2~8=On	SW3-2~8=On	SW3-2~8=On

Note

1. For SW2~3, the setting must be Off if there is no suggestion in table.
2. For JP105~109, the setting must be 1-2 if there is no suggestion in table.
3. Low means internal pull-down for address bus active.
4. The SPI interface is not available when the S5U13781P00C100 evaluation board is used with the S5U13U00P00C100 USB adapter board.

3.2 Configuration Switches

The S5U13781P00C100 evaluation board includes the following switch blocks which control the functions described in Table 3-2: “Switch Settings”. For jumper locations on the evaluation board, see Figure 3-1: “Configuration Switch and Jumper Locations (Red)” on page 10.

Table 3-2: Switch Settings

Switch	bit	On	Off	Comment
SW1	1	CNF0 is Pull Up (1)	CNF0 is Pull Down (0)	CNF[2:0] configuration. See Table 3-1: “Host Interface Pin Mapping”
	2	CNF1 is Pull Up (1)	CNF1 is Pull Down (0)	
	3	CNF2 is Pull Up (1)	CNF2 is Pull Down (0)	
	4	not used	not used	
SW2	1	UB# is Pull Up	UB# is not tied	Host interface pin termination when not used pin. See Table 3-1: “Host Interface Pin Mapping”
	2	LB# is Pull Up	LB# is not tied	
	3	RD# is Pull Up	RD# is not tied	
	4	not used	not used	
	5	DB2 is Pull Down	DB2 is not tied	
	6	DB3 is Pull Down	DB3 is not tied	
	7	DB4 is Pull Down	DB4 is not tied	
	8	DB5 is Pull Down	DB5 is not tied	
	9	DB6 is Pull Down	DB6 is not tied	
	10	DB7 is Pull Down	DB7 is not tied	
SW3	1	DB8 is Pull Down	DB8 is not tied	
	2	DB9 is Pull Down	DB9 is not tied	
	3	DB10 is Pull Down	DB10 is not tied	
	4	DB11 is Pull Down	DB11 is not tied	
	5	DB12 is Pull Down	DB12 is not tied	
	6	DB13 is Pull Down	DB13 is not tied	
	7	DB14 is Pull Down	DB14 is not tied	
	8	DB15 is Pull Down	DB15 is not tied	

= suggested settings

3.3 Configuration Jumpers

The S5U13781P00C100 evaluation board includes the following 2-pin, 3-pin and 4-pin jumper blocks which control the functions described in Table 3-3: “2-Pin Jumper Settings”, Table 3-4: “3-Pin Jumper Settings” and Table 3-5: “4-Pin Jumper Setting”. For jumper locations on the evaluation board, see Figure 3-1: “Configuration Switch and Jumper Locations (Red)” on page 10.

Table 3-3: 2-Pin Jumper Settings

Jumper	Position 1-2	No Jumper (Open)
JP101	Connect COREVDD Power Supply	Connect a current meter for power measurement
JP102 NOTE	Connect HIOVDD Power Supply to S5U13U00P00C100	No HIOVDD Power Supply to S5U13U00P00C100
JP103	Connect IOVDD Power Supply	Connect a current meter for power measurement
JP104	Connect PLLVDD Power Supply	Connect a current meter for power measurement
JP400	P12V is disabled	P12V is enabled
JP500	On board OSC (SG-210) is disabled	On board OSC (SG-210) is enabled

= suggested settings

Note

For normal S5U13781P00C100 operation, JP102 should be in Position 1-2. Also, when using the S5U13781P00C100 with the S5U13U00P00C100, JP102 should be in Position 1-2 (JP1 on the S5U13U00P00C100 must be in Position 1-2). For IOVDD current measurement, JP102 should be removed.

Table 3-4: 3-Pin Jumper Settings

Jumper	Position 1-2	Position 2-3	Off
JP105	WR# is from P1 and CN3	WR# is from P2	WR# is not connected
JP106	DB0 is from P1 and CN3	DB0 is from P2	DB0 is not connected
JP107	DB1 is from P1 and CN3	DB1 is from from P2	DB1 is not connected
JP108	AB0 is AB0	AB0 is TE	AB0 is not connected
JP109	DB8 is DB8	DB8 is TE	DB8 is not connected
JP501	Power supply for clock DIP Socket is connected with 3.3V	Power supply for clock DIP Socket is connected with 5V	Power supply for clock DIP Socket is not connected

= suggested settings

Note

The SPI interface is not available when the S5U13781P00C100 evaluation board is used with the S5U13U00P00C100 USB adapter board.

Table 3-5: 4-Pin Jumper Setting

Jumper	Position 1-2	Position 3-4
JP502	CLKI is connected with on board OSC (24MHz)	CLKI is connected with clock DIP socket

Table 3-5: 4-Pin Jumper Setting

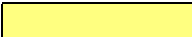
 = suggested settings

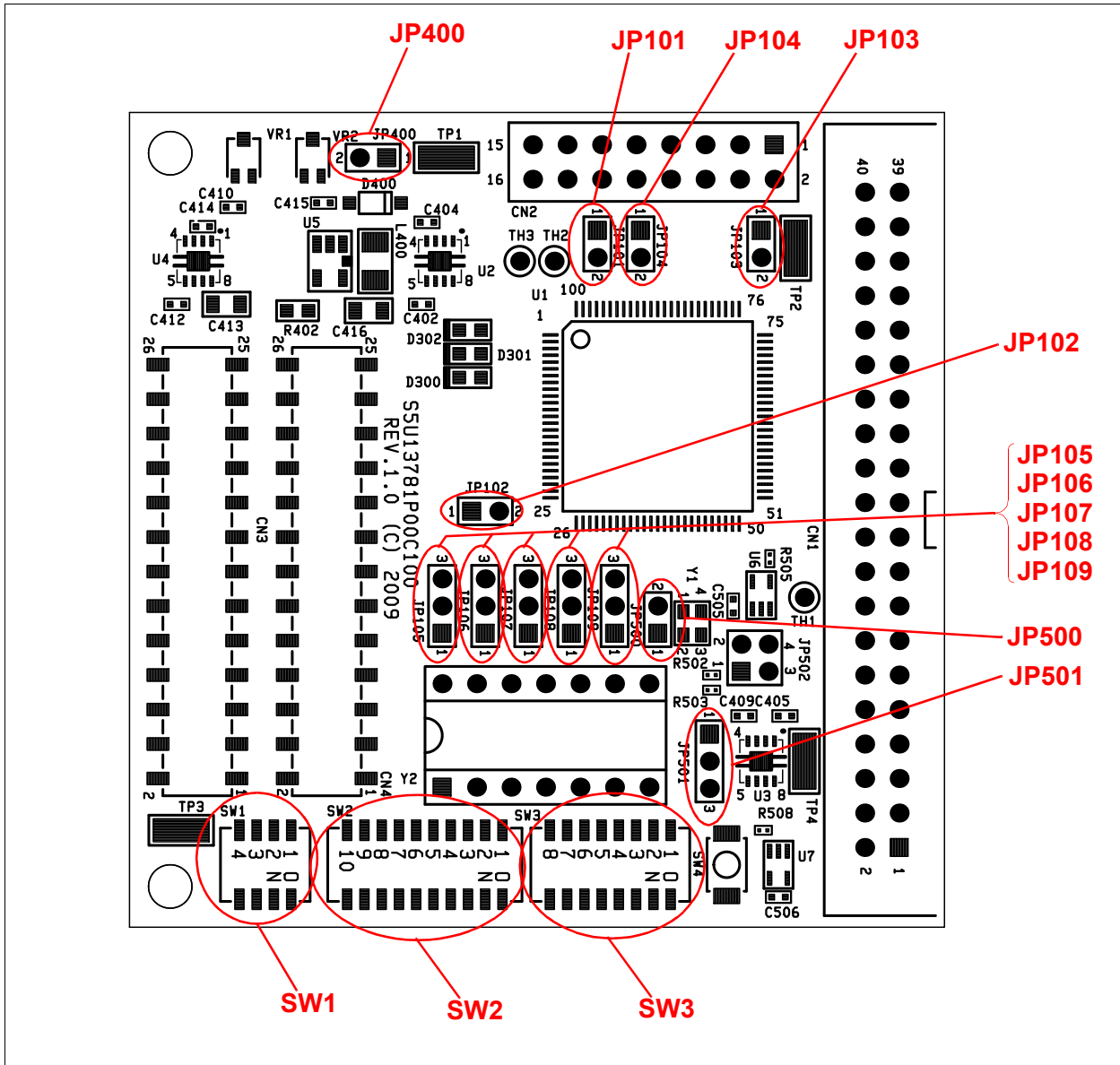

Figure 3-1: Configuration Switch and Jumper Locations (Red)

3.4 Zero Ohm Resistor Configuration

Between the S5U13U00P00C100 connector (P1, P2) and the S1D13781 there are zero ohm resistors. Resistor R346 is not populated.

3.5 Power Requirements

3.5.1 IOVDD, COREVDD, PLLVDD

The S5U13781P00C100 evaluation board is designed to generate COREVDD, PLLVDD and IOVDD from 5V via the S5U13U00P00C100 USB adapter board or connector CN4. Since PLLVDD and COREVDD must be same, these two voltages are generated by one voltage regulator, separated by an inductance. 5V must be supplied from the S5U13U00P00C100 or CN4. HIOVDD for the S5U13U00P00C100 should be supplied from the S5U13781P00C100 (both JP102 on the S5U13781P00C100 evaluation board and JP1 on the S5U13U00P00C100 USB adapter board should be set to position 1-2). These power supplies are adjustable. See Table 3-6: “S5U13781P00C100 Power Mapping” for detail.

3.5.2 3.3V

The S5U13781P00C100 evaluation board is designed to generate 3.3V for on board OSC from 5V via the S5U13U00P00C100 USB adapter board or connector CN4. 5V must be supplied from the S5U13U00P00C100 or CN4. The 3.3V power supply is fixed output. See Table 3-6: “S5U13781P00C100 Power Mapping” for detail.

3.5.3 Backlight Power Supply for LCD Panel

The S5U13781P00C100 evaluation board is designed to generate backlight power supply for LCD panel from 5V via the S5U13U00P00C100 USB adapter board or connector CN4. The 5V must be supplied from the S5U13U00P00C100 or CN4. This power supply is adjustable. See Table 3-6: “S5U13781P00C100 Power Mapping” for detail.

Table 3-6: S5U13781P00C100 Power Mapping

Name	Purpose	Adj.	Range
COREVDD	S1D13781 COREVDD 1.5V Fixed	—	1.5V
PLLVDD	S1D13781 PLLVDD 1.5V Fixed		
IOVDD\	S1D13781 IOVDD 1.8/3.3V Typical	VR1	1.5~3.8V
3.3V	SG-210 VDD 3.3V Fixed	—	3.3V
P12V	Backlight for panel, 12V Typical	VR2	12~30V

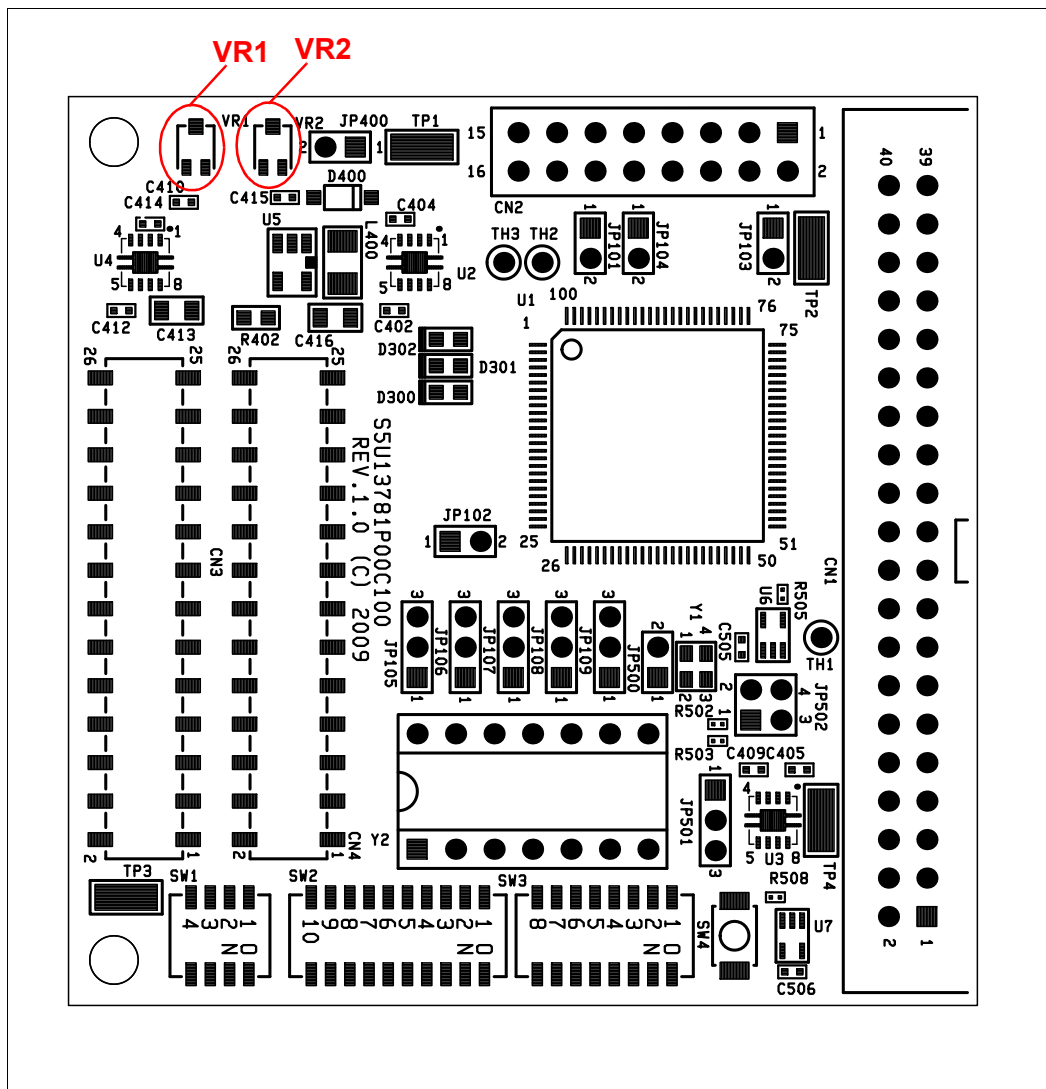

Figure 3-2: Voltage Adjustment Locations (Red)

3.6 LED Status Indicators

The S5U13781P00C100 evaluation board has 3 LED status indicators which provide a quick visual status of the following conditions as described in Table 3-7: “LED Status Indicators”.

Table 3-7: LED Status Indicators

LED	Color	Signal	Comment
HB	RED	HEARTBEAT	HEARTBEAT from the S5U13U00P00C100
ENUM	ORANGE	ENUMARETED	ENUMARETED from the S5U13U00P00C100
POWER	GREEN	5V	5.0V is present from the S5U13U00P00C100 or CN4

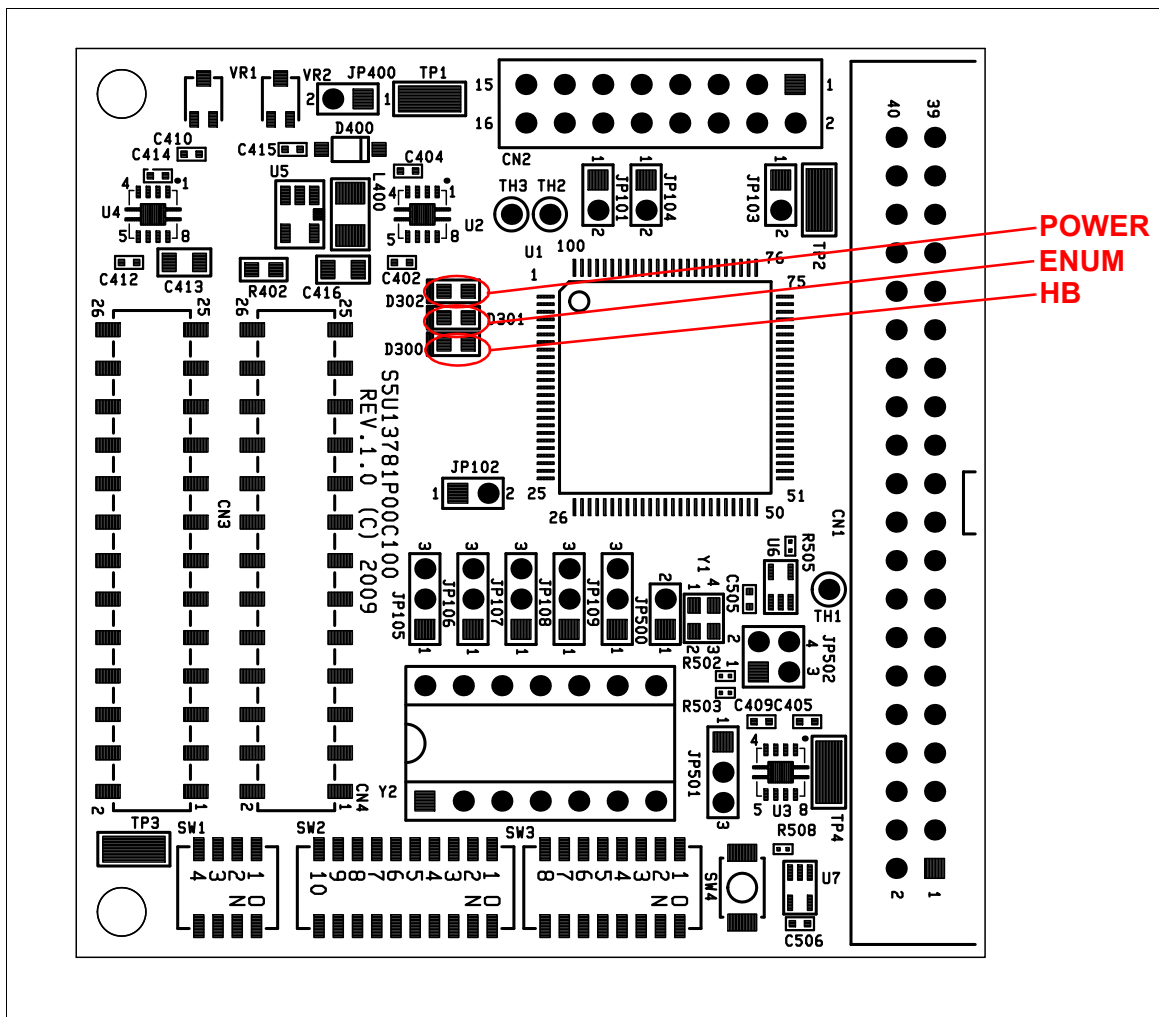

Figure 3-3: LED Locations (Red)

Chapter 4 Connectors

4.1 CN1, CN2 Panel Interface Connector

The LCD interface uses the VS, HS, DE, PCLK and PDT[23:0] pins. All signals on these pins are available on connectors CN1 and CN2.

Connectors CN1 and CN2 are 0.1" x 0.1", 40-pin headers (20 x 2) for CN1, 16-pin headers (8 x 2) for CN2. See Figure 4-1: "Host and Panel Bus Connector Location (CN1, CN2, CN3, CN4)" on page 15 for the location of these connectors. For the pinout of connectors CN1 and CN2, see Section Chapter 7, "Schematic Diagrams" on page 22.

4.2 CN3, CN4 Host Bus Interface Connector

All S1D13781 host interface pins are available on connectors CN3 and CN4. This allows the S5U13781P00C100 evaluation board to be connected to a variety of development platforms. For S1D13781 host interface pin mapping, see Table 3-1: "Host Interface Pin Mapping," on page 7.

See Figure 4-1: "Host and Panel Bus Connector Location (CN1, CN2, CN3, CN4)" on page 15 for the location of host bus connectors CN3 and CN4. CN3 and CN4 are 0.1" x 0.1" 26-pin header (13x2). For the pinout of connectors CN3 and CN4, see Section Chapter 7, "Schematic Diagrams" on page 22.

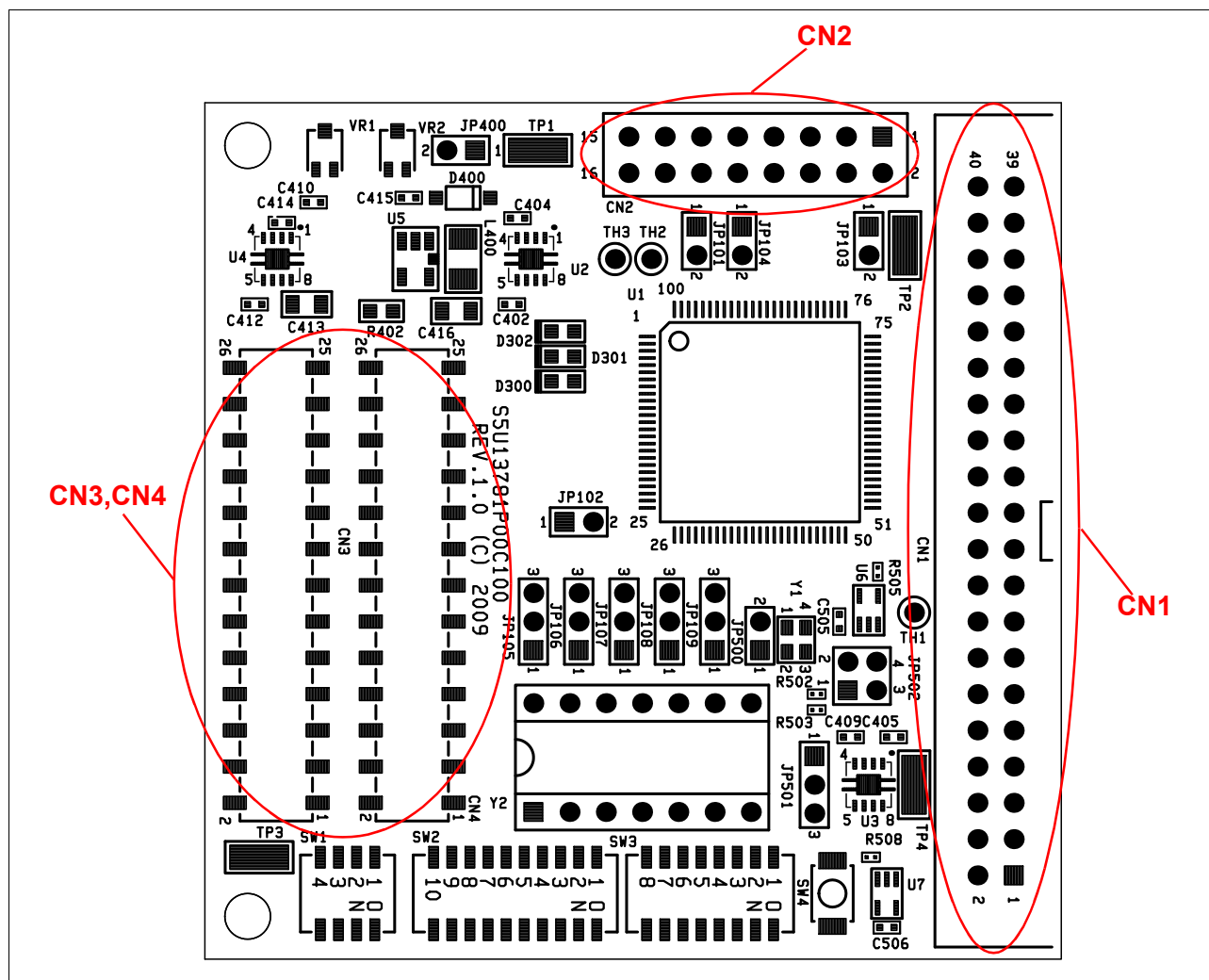

Figure 4-1: Host and Panel Bus Connector Location (CN1, CN2, CN3, CN4)

4.3 P1, P2 Connecting to the Epson S5U13U00P00C100 USB Adapter Board

The S5U13781P00C100 evaluation board is designed to connect to a S5U13U00P00C100 USB Adapter Board. The USB adapter board provides a simple connection to any computer via a USB 2.0 connection. The S5U13781P00C100 directly connects to the USB adapter board through connectors P1 and P2.

Note

The SPI interface is not available when the S5U13781P00C100 evaluation board is used with the S5U13U00P00C100 USB adapter board.

The S5U13U00P00C100 USB adapter board supplies the 5V power required by the S5U13781P00C100 evaluation board. The S5U13781P00C100 evaluation board then supplies the HIOVDD for the S5U13U00P00C100 USB adapter board. Therefore, both JP102 on the S5U13781P00C100 evaluation board and JP1 on the S5U13U00P00C100 USB adapter board should be set to position 1-2.

Connectors

When the S5U13781P00C100 is connected to the S5U13U00P00C100 USB Adapter board, there are 2 LEDs on the S5U13781P00C100 which provide a quick visual status of the USB adapter. HB (D300) blinks to indicate that the USB adapter board is active. ENUM (D301) turns on to indicate that the USB has been enumerated by the PC.

The following diagram shows the location of connectors P1 and P2. P1 and P2 are 2mm x 2mm, 40-pin headers (20 x 2) located on the underside of the board.

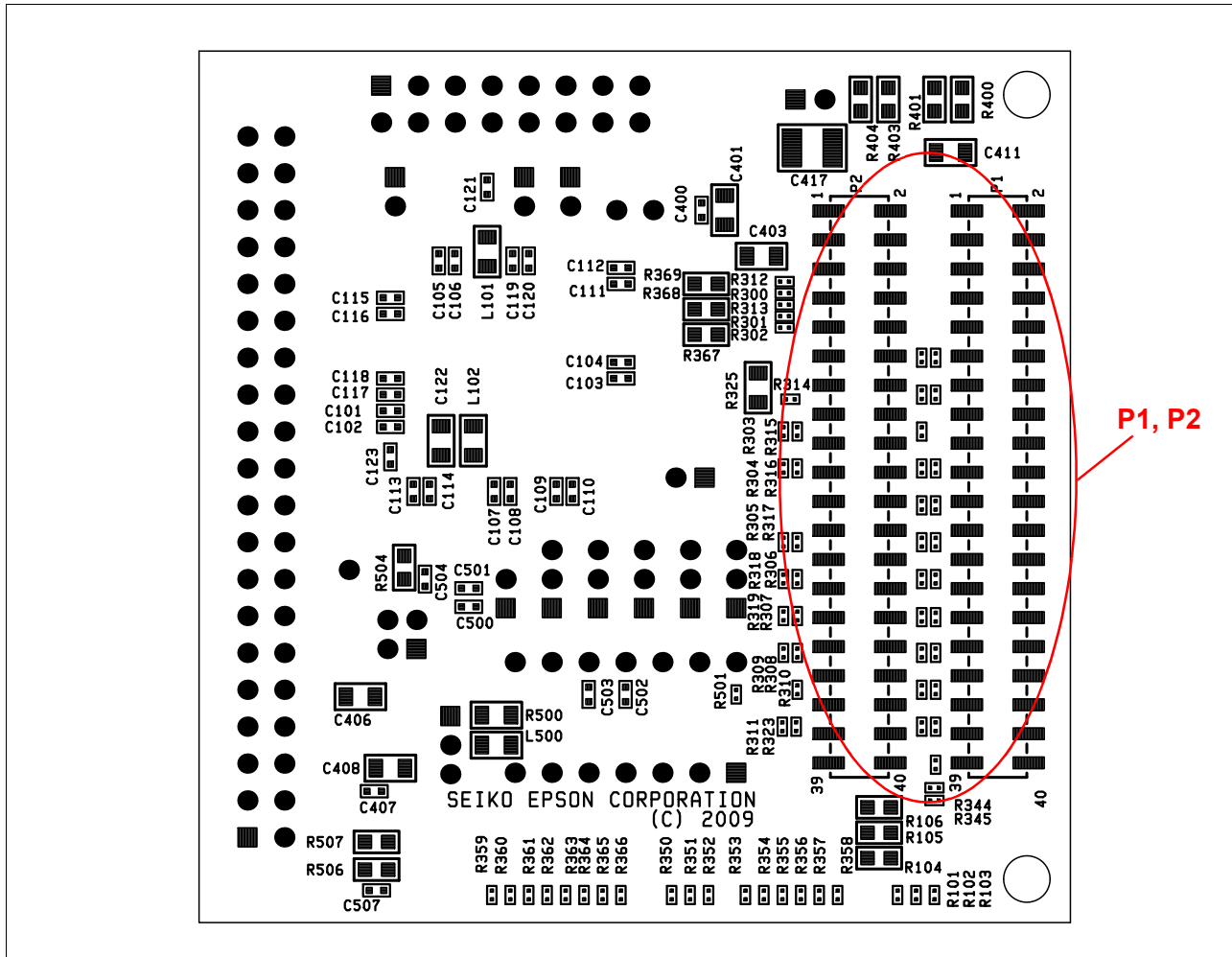

Figure 4-2: USB Adapter Connector Locations (P1, P2)

For the pinout of connectors P1 and P2, see Section Chapter 7, “Schematic Diagrams” on page 22.

Note

A windows driver must be installed on the PC when the S5U13781P00C100 is used with the S5U13U00P00C100 USB Adapter Board. The SID13xxxUSB driver is available at vdc.epson.com.

Chapter 5 Technical Description

5.1 Current Measurement

Current measurement can be performed individually for the following S1D13781 power supplies: COREVDD, PLLVDD, IOVDD. For a details on which jumper block is used for each power supply, refer to Table 3-3: “2-Pin Jumper Settings,” on page 9.

To measure current for a particular S1D13781 power supply, remove the corresponding jumper shunt and place an ammeter on the jumper terminals to measure the current draw. Use the lowest possible range for the measurement to minimize loading from the ammeter.

For IOVDD current measurement, shunts for JP102 and JP103 should be removed and an ammeter connected across JP103. For IOVDD current measurement while using the S5U13U00C100, the JP102 shunt must be removed because the S5U13781P00C100 supplies HIOVDD for the S5U13U00P00C100 via JP102. JP1 on S5U13U00P00C100 must be set to position 2-3.

Note

Attaching an ammeter while doing other tests can cause a voltage drop across the ammeter and may produce invalid test results.

5.2 Oscillator Support for CLKI input

The S5U13781P00C100 evaluation board has an on-board 24MHz oscillator (Y1) which drives the input for the S1D13781 CLKI pin. The CLKI source can also be provided by DIP socket (Y2) which accepts 3.3V or 5V 14-pin DIP oscillators based on JP501.

The CLKI source selection is determined by jumper setting on JP502. For details on configuring the CLKI source, refer to Table 3-5: “4-Pin Jumper Setting,” on page 9.

5.3 Hardware Reset

The S5U13781P00C100 evaluation board has an on-board reset IC which drives the RESET# input pin on the SID13781. This occurs when push button SW4 is pressed.

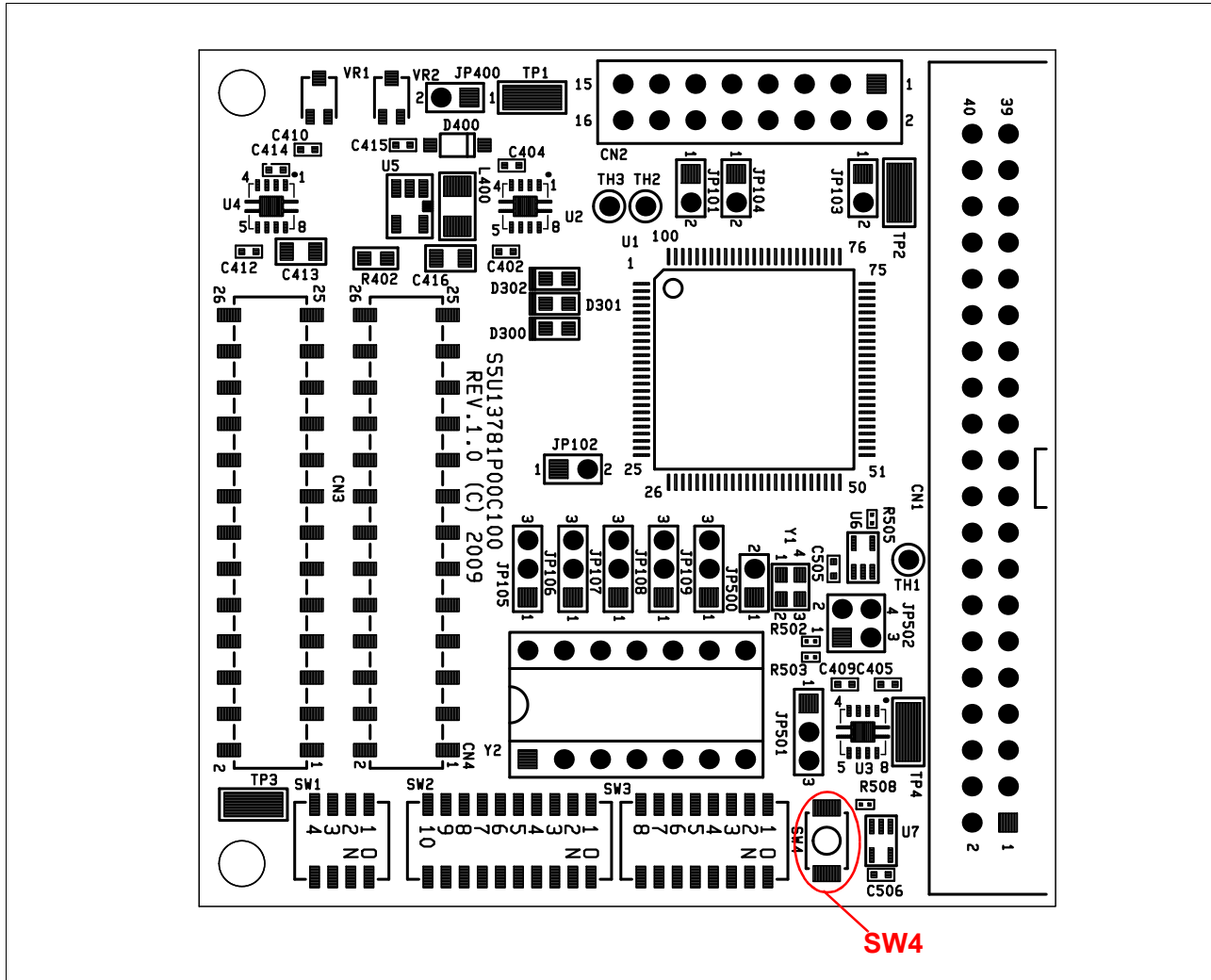

Figure 5-1: Reset Switch (SW4) Location

Chapter 6 Parts List

Table 6-1 : S5U13781P00C100 Parts List

Item	Qty	Reference	Part	Description	Manufacture Part No. / Comments
1	1	U1	S1D13781F	LCD Controller QFP15-100 0.5mm Pitch	EPSON S1D13781F
2	1	U2	TPS73615DRB	Single Channel LDO Fixed	TI TPS73615DRB
3	1	U3	TPS73633DRB	Single Channel LDO Fixed	TI TPS73633DRB
4	1	U4	TPS73601DRB	Single Channel LDO Adjustable	TI TPS73601DRB
5	1	U5	LM2733YMF	0.6MHz Boost Converters With 40V Internal FET Switch	NS LM2733YMF
6	1	U6	SN74LVC1G126DCK	SINGLE BUS BUFFER SC70-5	TI SN74LVC1G126DCK
7	1	U7	TPS3801-01DCKR	SUPPLY VOLTAGE SUPERVISORS Vref 1.14V Delay 200ms	TI TPS3801-01DCKR
8	1	C415	GRM1552C1H101JZ01D	cap 100p 1005	MURATA
9	1	C123	GRM155B11H102KA01D	cap 1000p 1005	MURATA
10	3	C404, C409, C414	GRM155B11E103KA01D	cap 10n 1005	MURATA
11	14	C102, C104, C106, C108, C110, C112, C114, C116, C118, C120, C501, C503, C505, C507	GRM155B11E103KA01D	cap 0.01u 1005	MURATA
12	21	C101, C103, C105, C107, C109, C111, C113, C115, C117, C119, C121, C400, C402, C405, C407, C410, C412, C500, C502, C504, C506	GRM155R71C104KA88D	cap 0.1u 1005	MURATA
13	1	C416	GRM21BB31E475KA75L	cap 4.7u 16v 2012	MURATA
14	1	C417	GRM32ER71H475KA88L	cap 4.7u 50v 3225	MURATA
15	7	C122, C401, C403, C406, C408, C411, C413	GRM21BB31C106KE15L	cap 10u 16v 2012	MURATA

Parts List

Table 6-1 : S5U13781P00C100 Parts List

Item	Qty	Reference	Part	Description	Manufacture Part No. / Comments
16	45	R300, R301, R302, R303, R304, R305, R306, R307, R308, R309, R310, R311, R312, R314, R315, R316, R317, R318, R319, R320, R321, R322, R323, R324, R326, R327, R328, R329, R330, R331, R332, R333, R334, R335, R336, R337, R338, R339, R340, R341, R342, R343, R344, R345, R508	ERJ-1GE0R00C	res 0 0603	Panasonic
17	2	R325, R500	RK73Z2ATTD	res 0 2012	KOA
18	2	R367, R368	RK73B1JTTD 331J	res 330 1608	KOA
19	1	R369	RK73B1JTTD 621J	res 620 1608	KOA
20	20	R101, R102, R103, R350, R351, R352, R353, R354, R355, R356, R357, R358, R359, R360, R361, R362, R363, R364, R365, R366	ERJ-1GEJ102C	res 1k 0603	Panasonic
21	1	R404	RK73H1JTTD 1202F	res 12k 1608	KOA
22	1	R401	RK73B1JTTD 223J	res 22k 1608	KOA
23	5	R104, R105, R106, R400, R504	RK73B1JTTD 473J	res 47k 1608	KOA
24	2	R402, R403	RK73B1JTTD 104J	res 100k 1608	KOA
25	3	R502, R503, R505	MCR006YZPF33R0	res 33 1% 0603	ROHM
26	1	R506	RK73H1JTTD 5621F	res 5.62k 1% 1608	KOA
27	1	R507	RK73H1JTTD 4532F	res 45.3k 1% 1608	KOA
28	2	R313, R501	NM	res NM 0603	not mounted
29	2	VR1, VR2	ST-2TA200k(204)	SMD Trimming Potentiometer 200k	COPAL ST-2TA200k(204)
30	1	D300	SML-310VT	LED red 1608	ROHM SML-310VT
31	1	D301	SML-310DT	LED orange 1608	ROHM SML-310DT

Table 6-1 : S5U13781P00C100 Parts List

Item	Qty	Reference	Part	Description	Manufacture Part No. / Comments
32	1	D302	SML-310PT	LED green 1608	ROHM SML-310PT
33	1	D400	MBR0540	DIODE SCHOTTKY 40V 0.5A SOD123	ON Semiconductor MBR0540
34	3	L101, L102, L500	BLM21P	FERRITE CHIP 220 OHM 2000mA 0805	MURATA BLM21P
35	1	L400	LQH32CN100K23L	INDUCTOR 10UH 10% 300MA 1210	MURATA LQH32CN100K23L
36	1	Y1	SG-210SCB 24MHz or FCXO-05 24MHz	CRYSTAL OSCILLATOR 24MHz	EPSON SG-210SCB 24MHz or RIVER ELETEC FCXO-05 24MHz
37	1	Y2	J143D-GT	IC Socket 14pin DIP	JC J143D-GT
38	1	CN1	HIF3FC-40PA- 2.54DSA	Box Connector 2.54mm 40pin	HIROSE
39	1	CN2	HIF3H-16PA-2.54DSA	Pin Header 2.54mm 16pin	HIROSE
40	2	CN4, CN3	TCHM23-70-026SM2- 000R	Pin Header 2.54mm 26pin SMD	TOKIWA
41	6	JP101, JP102, JP103, JP104, JP400, JP500	PRPN021PAEN	2mm 2 pos Jumper	SULLINS
42	6	JP105, JP106, JP107, JP108, JP109, JP501	PRPN031PAEN	2mm 3 pos Jumper	SULLINS
43	1	JP502	PRPN022PAEN	2mm 2x2 pos Jumper	SULLINS
44	2	P1, P2	PRPN202MAMS-RC	Pin Header 2mm 40pin SMD	SULLINS
45	1	SW1	CHS-04A	Slide Switch 4bit	COPAL
46	1	SW2	CHS-10A	Slide Switch 8bit	COPAL
47	1	SW3	CHS-08A	Slide Switch 10bit	COPAL
48	1	SW4	SKRKAEE010	SMD Tactile Switches 3.9x2.9x2.0mm	ALPS
49	3	TH1, TH2, TH3	0.9mm dia	Through Hole 0.9mm dia	-
50	4	TP1, TP2, TP3, TP4	HK-2-S	Test Point	MAC8
51	12	SH101, SH102, SH103, SH104, SH105, SH106, SH107, SH108, SH109, SH400, SH501, SH502	SPN02SYBN-RC	.079 in. Jumper Shunt	SULLINS
52	2	-	EP-6	Spacer M3x6mm	MAC8
53	2	-	3M-5	Screw M3x5mm	MAC8

Chapter 7 Schematic Diagrams

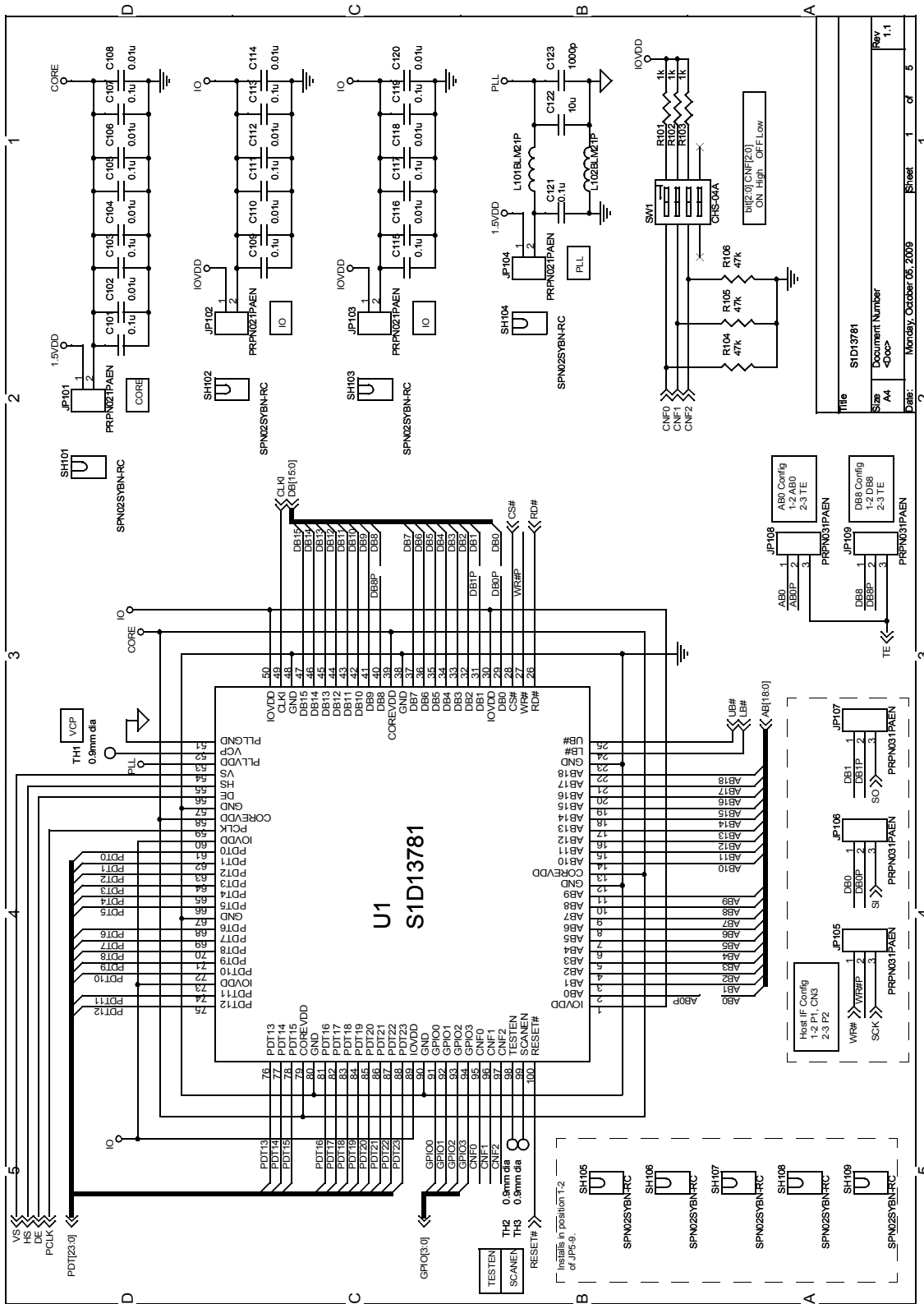
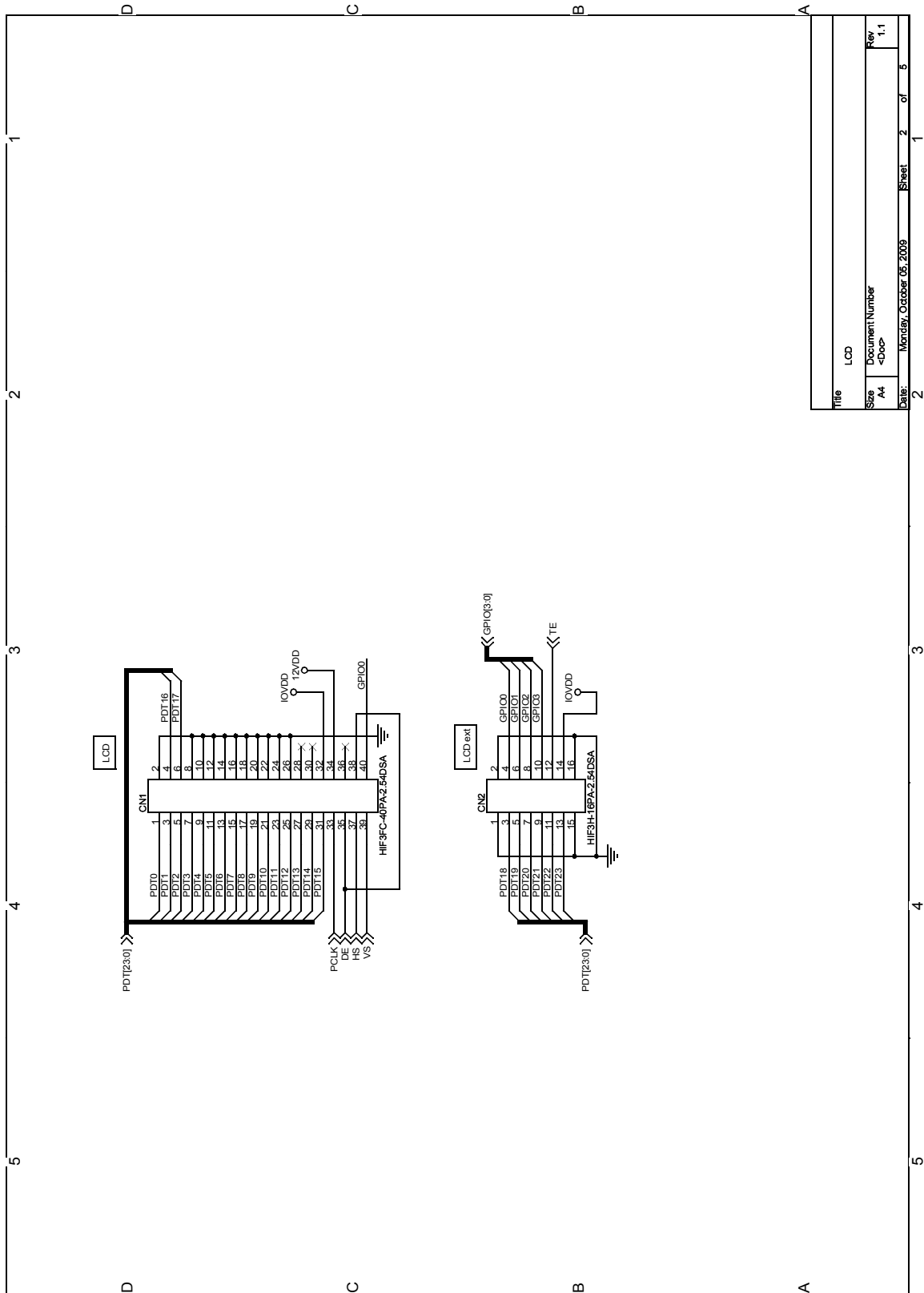

Figure 7-1: S5U13781P00C100 Schematics (1 of 5)



Title	LCD
Size	A4
Document Number	<Doc>
Rev	1.1
Date	Monday, October 05, 2009
Sheet	2 of 5

Figure 7-2: S5U13781P00C100 Schematics (2 of 5)

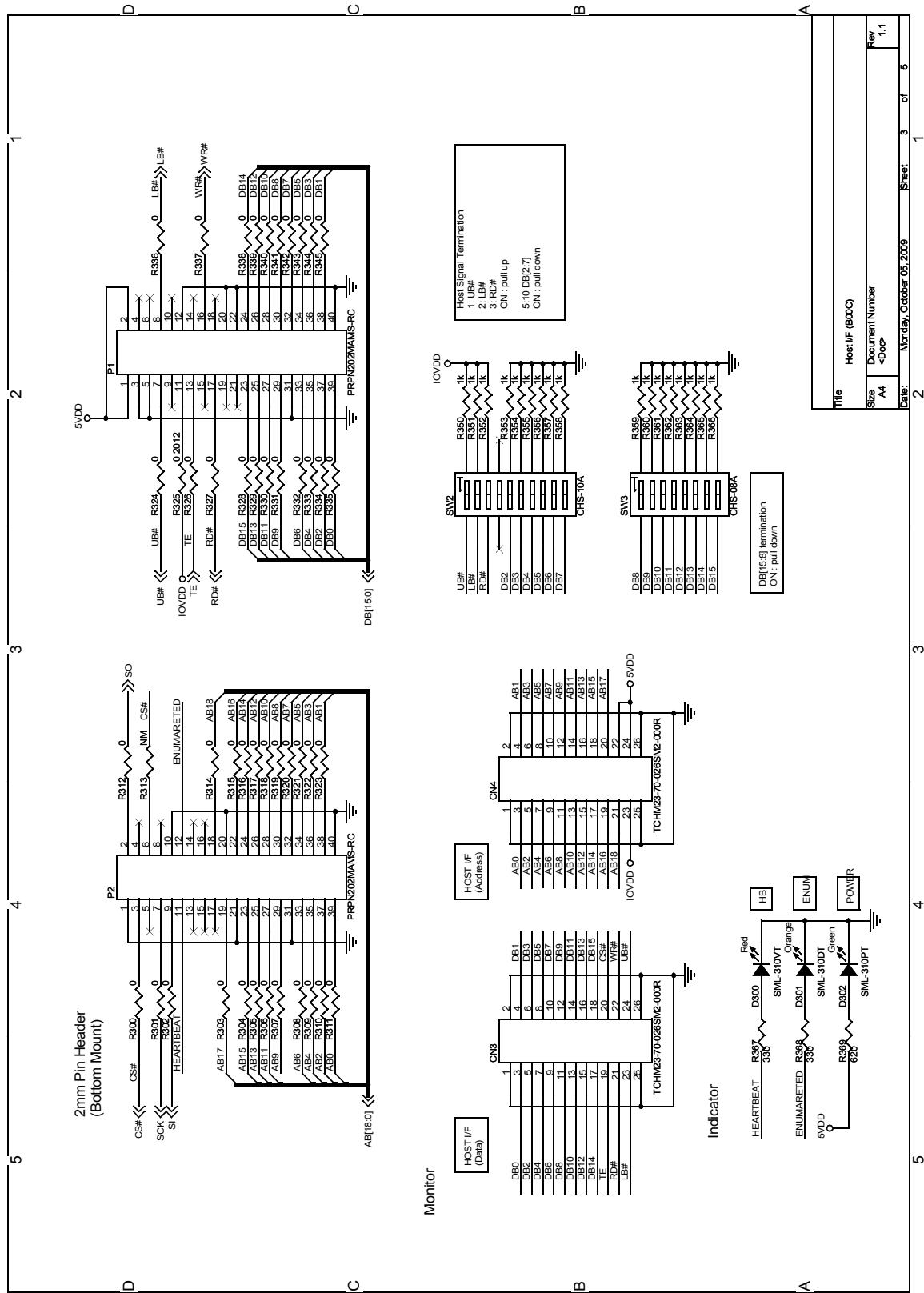

Figure 7-3: S5U13781P00C100 Schematics (3 of 5)

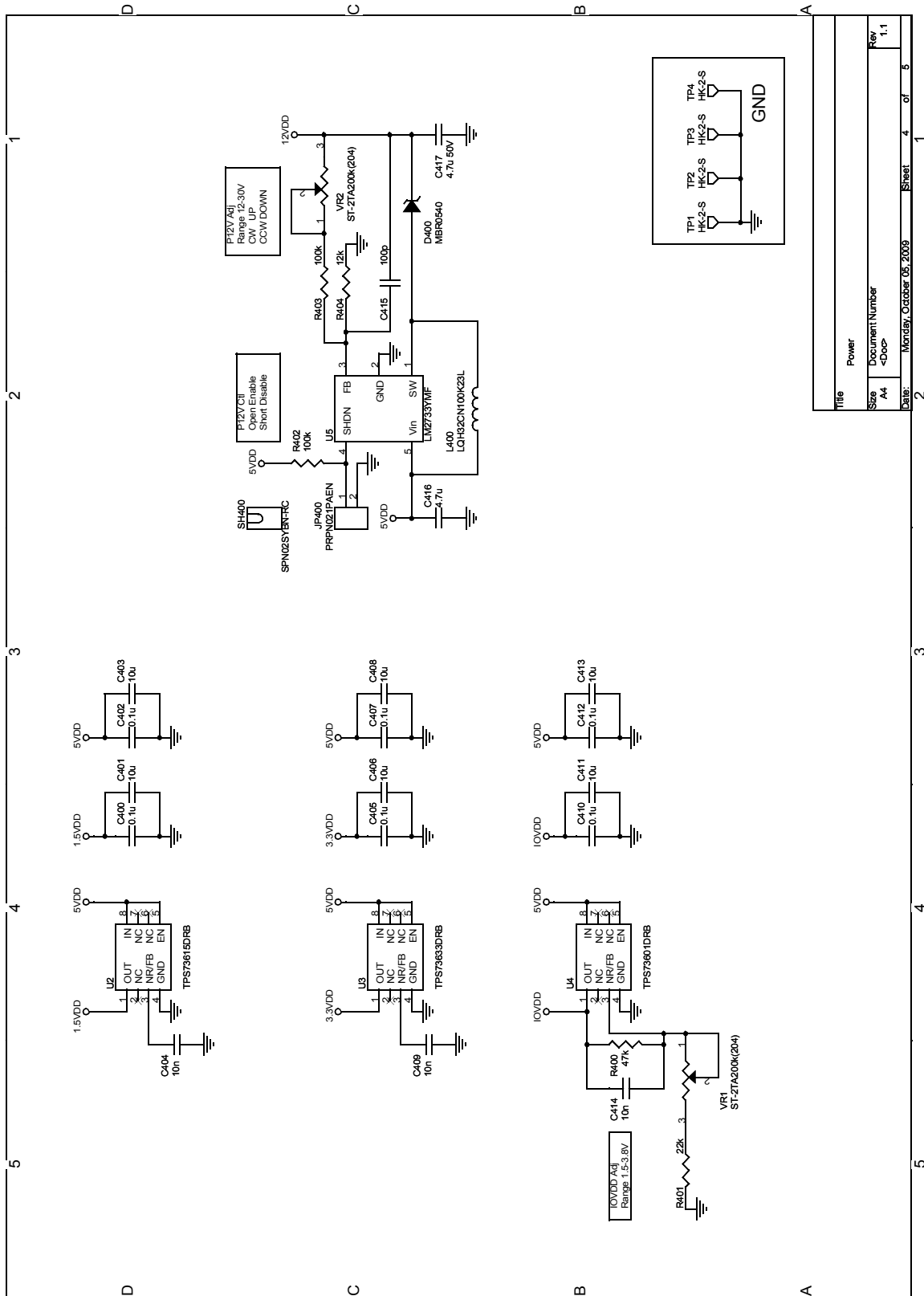

Figure 7-4: S5U13781P00C100 Schematics (4 of 5)

Title		Power	
Size	Document Number	Sheet	Rev
A4	<Doc>	4 of 5	1.1
Date	Monday, October 05, 2009		Sheet
			1

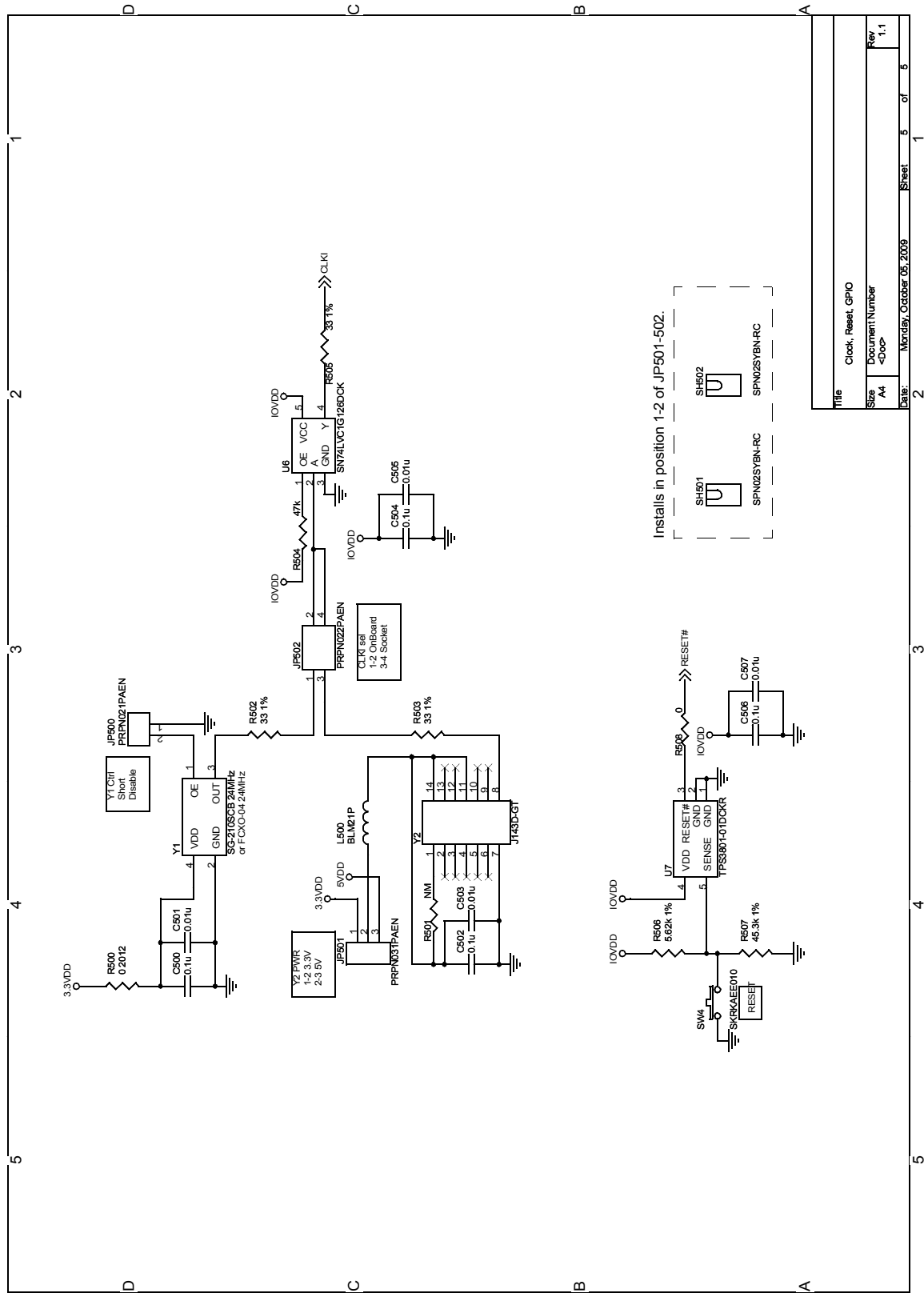

Figure 7-5: S5U13781P00C100 Schematics (5 of 5)

Chapter 8 Board Layout

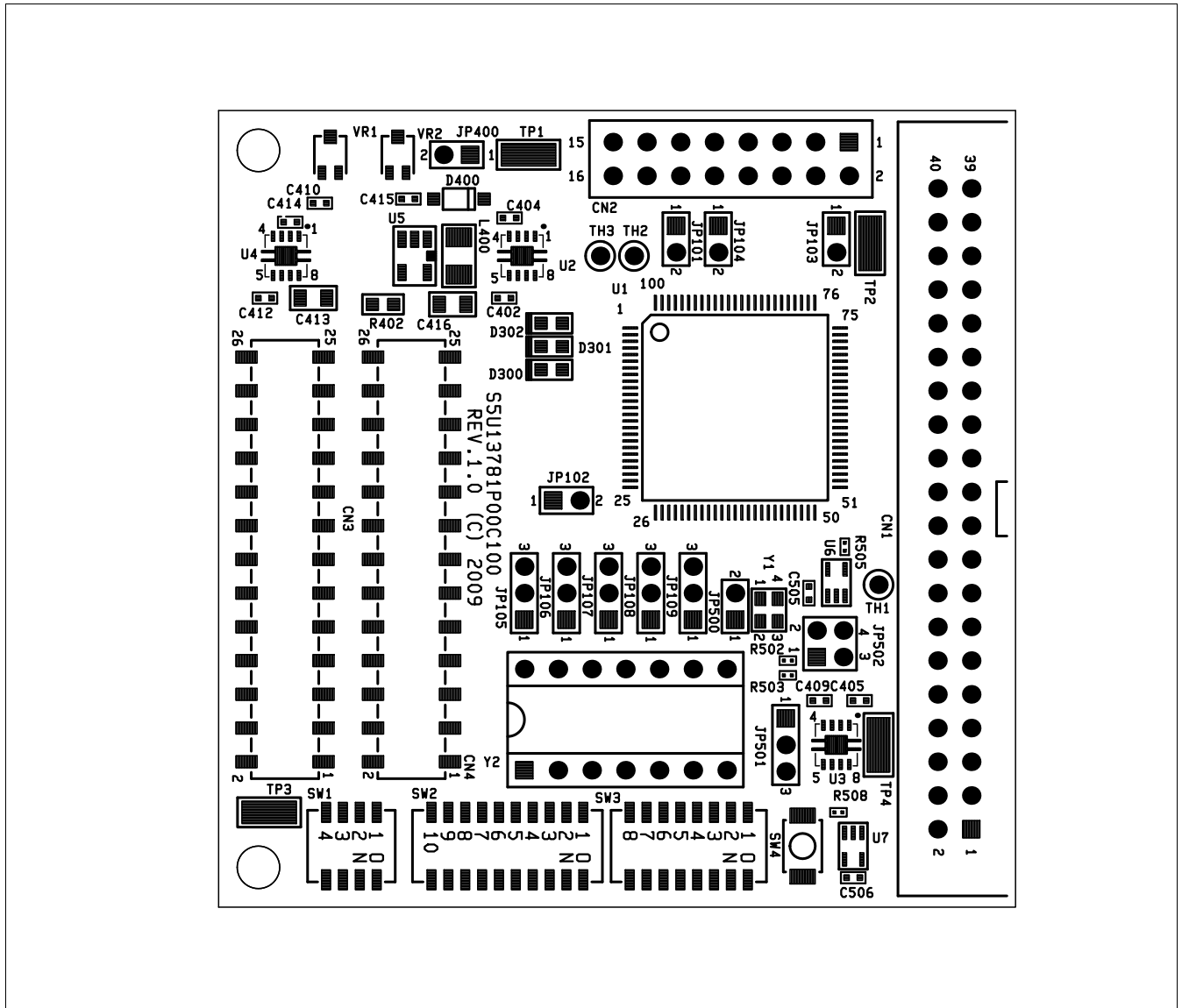

Figure 8-1: S5U13781P00C100 Board Layout - Top View

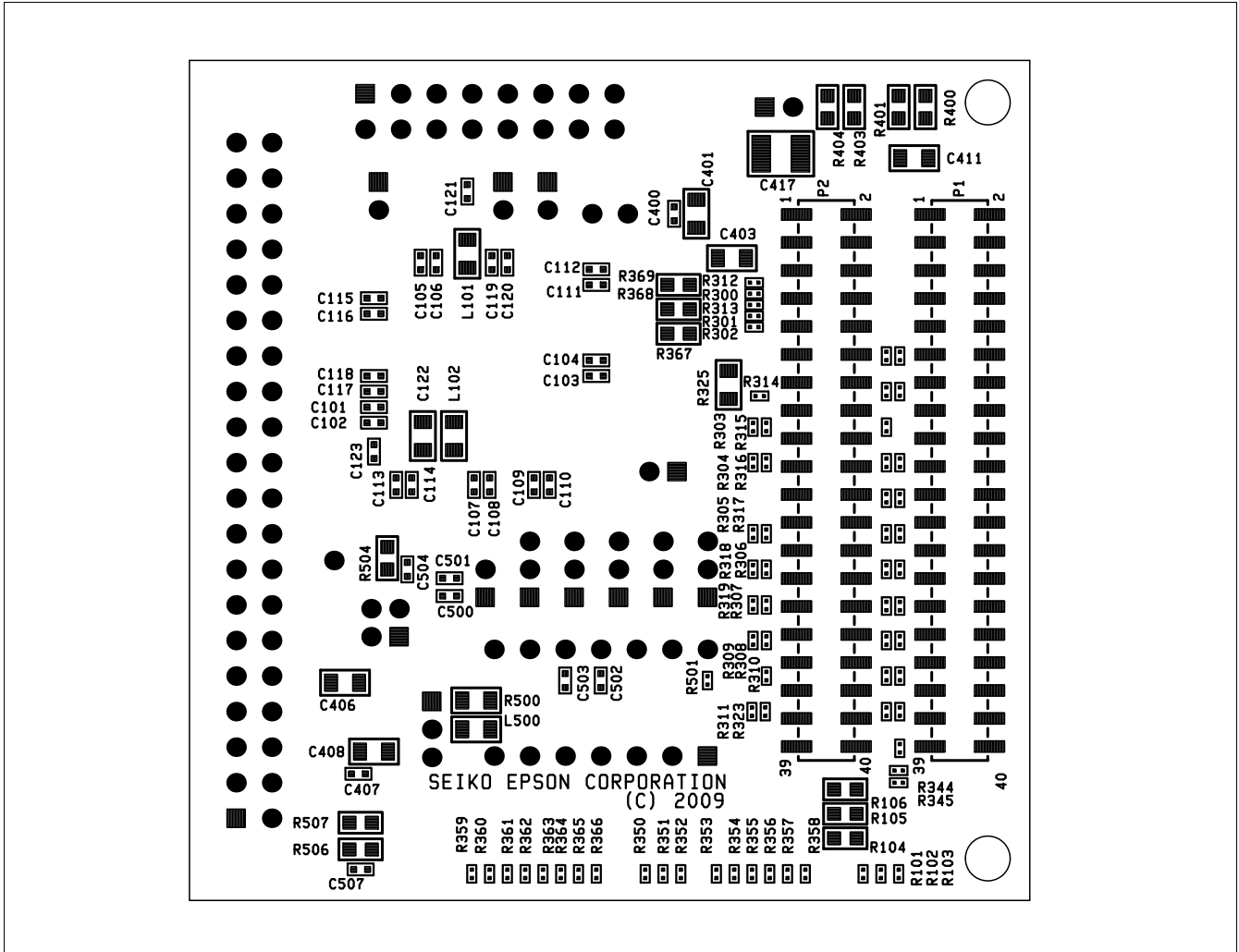

Figure 8-2: S5U13781P00C100 Board Layout - Bottom View

Chapter 9 Change Record

X94A-G-001-01 Revision 1.4 - Issued: March 30, 2018

- Updated address/contact page
- Updated Epson web page and email address
- Minor formatting changes

X94A-G-001-01 Revision 1.3 - Issued: October 6, 2010

- chapter 3.1 CNF[2:0] Configuration - changes to SPI pin mapping for WR#, DB0 and DB1 pins
- chapter 3.3 Configuration Jumpers - table 3-4, *3-Pin Jumper Settings*, changes to JP105, JP106, JP107 and JP108 setting descriptions
- chapter 7 Schematic Diagrams - change settings for “Host IF Config” in figure 7-1, *S5U13781P00C100 Schematics (1 of 5)*

X94A-G-001-01 Revision 1.2 - Issued: July 20, 2010

- add “Evaluation board/kit and Development tool important notice” above Copyright Notice on second page
- chapter 2 Features - add note “The SPI interface is not available when the S5U13781P00C100...” and “or RIVER ELETEC FCXO-05” to bulleted text “On-board 24MHz crystal...”
- chapter 3.1 CNF[2:0] Configuration - add note 4 “The SPI interface is not available when the S5U13781P00C100...” after table 3-1, *Host Interface Pin Mapping*
- chapter 3.3 Configuration Jumpers - changes to table 3-4, *3-Pin Jumper Settings*, Position 2-3 descriptions and add note “The SPI interface is not available when the S5U13781P00C100...” after table 3-4
- chapter 4.3 P1, P2 Connecting to the Epson S5U13U00P00C100 USB Adapter Board - add note “The SPI interface is not available when the S5U13781P00C100...”
- chapter 6 Parts List - in table 6-1 add reference to “FCXO-05 24MHz” to Item 36 Description and Manufacture Part No.
- chapter 7 Schematic Diagrams - add reference to “FCXO-05 24MHz” to Y1 in figure 7-5, *S5U13781P00C100 Schematics (5 of 5)*

X94A-G-001-01 Revision 1.1 - Issued: October 22, 2009

- globally change S5UUSBB00C to S5U13U00P00C100
- globally change PIOVDD to IOVDD
- chapter 1 Introduction - in paragraph two, change S5U13USBP00C100 to S5U13U00P00C100
- chapter 2 Features - in bullet three, change S5U13USBP00C100 to S5U13U00P00C100
- chapter 3.3 Configuration Jumpers - changes to table 3-3, *2-Pin Jumper Settings*, and add note for table
- chapter 4.3 P1, P2 Connecting to the Epson S5U13U00P00C100 USB Adapter Board - rewrite second paragraph
- chapter 5.1 Current Measurement - rewrite the second paragraph
- Chapter 7 Schematic Diagrams - update all figures for single IOVDD

Change Record

X94A-G-001-01 Revision 1.0 - Issued: August 19, 2009

- initial release

Chapter 10 Sales and Technical Support

For more information on Epson Display Controllers, visit the Epson Global website.

https://global.epson.com/products_and_drivers/semicon/products/display_controllers/



For Sales and Technical Support, contact the Epson representative for your region.

https://global.epson.com/products_and_drivers/semicon/information/support.html

