

**Drive Recorder IC
Dual Camera Controller with JPEG Encoder**



Preliminary

DESCRIPTION

The S2S65A30 is an image controller IC with additional convenient features and enhanced functions compared to the conventional IC S2S65A00. In addition to these conventional functions, it has an input image-correction function achieved by real-time image processing, an Interlace/Progressive conversion function that allows easy interlace camera connection, a replay function of recorded images and a high-speed write function to a SD card. The operating-temperature accuracy guarantees -40°C to +85°C. Compatible with conventional IC pins, the software is also upper-compatible with the S2S65A00. It is an optimum controller IC for image recording drive recorders.

FEATURES

- Suppresses absolute black (underexposure) and absolute white (overexposure) and corrects brightness by image processing for clear image acquisition
- Allows Interlace camera connection by the Interlace/Progressive conversion function
- Real-time recording of JPEG images to a SD card
- Realizes the image replay function by decoding JPEG images
- Compatible with S2S65A00 pins
- Software is upper-compatible with S2S65A00

SPECIFICATIONS

Image Processing Unit

Camera interface	8-bit parallel interface × 2 ch
Resolution	SXGA (When using camera 1 ch), VGA and QVGA
JPEG encoder/decoder	Encoder × 1 Encoder/decoder (switching) × 1
Camera input data format	YUV4:2:2
I/P conversion	Interlace <-> progressive conversion (NTSC, PAL)
Image correction	Absolute black (underexposure), absolute white (overexposure) and brightness correction

External Storage

Compact Flash Card interface	Complies with CF+ spec. Rev.1.4. and supports True IDE mode
SD Card Memory interface	Complies with SD memory card physical layer spec. ver.2.0. and supports 1-bit/4-bit interface

Others

Moving object detection	Detects 4 x 4 area of an image
General-purpose I/O	82 pcs (at Max.)
SPI	Clock synchronous serial interface
Serial interface	UART: Software compatible with 16,550 x 3 channels
I ² C bus	Master (for camera control or general purpose)
I ² S bus	For input/output of voice/audio
USB 2.0-HS (Device)	For communication with PC
ADC	Ch:8/ Resolution:10bit/ ConversionTime:10us
External Flash ROM	UP to 16 MB (Static memory available: up to 16 MB)
External SDRAM	Up to 512 MB
Supply voltage	1.8 V (core), 3.3 V (I/O), 2.4-3.6 V (camera I/O)
Package	PFBGA-280 pin (PFBGA16 U-280:16 ×16 ×1.2 mm, 0.8 mm ball pitch) Compatible with S2S65A00 pins

S2S65A30

■ BLOCK DIAGRAM

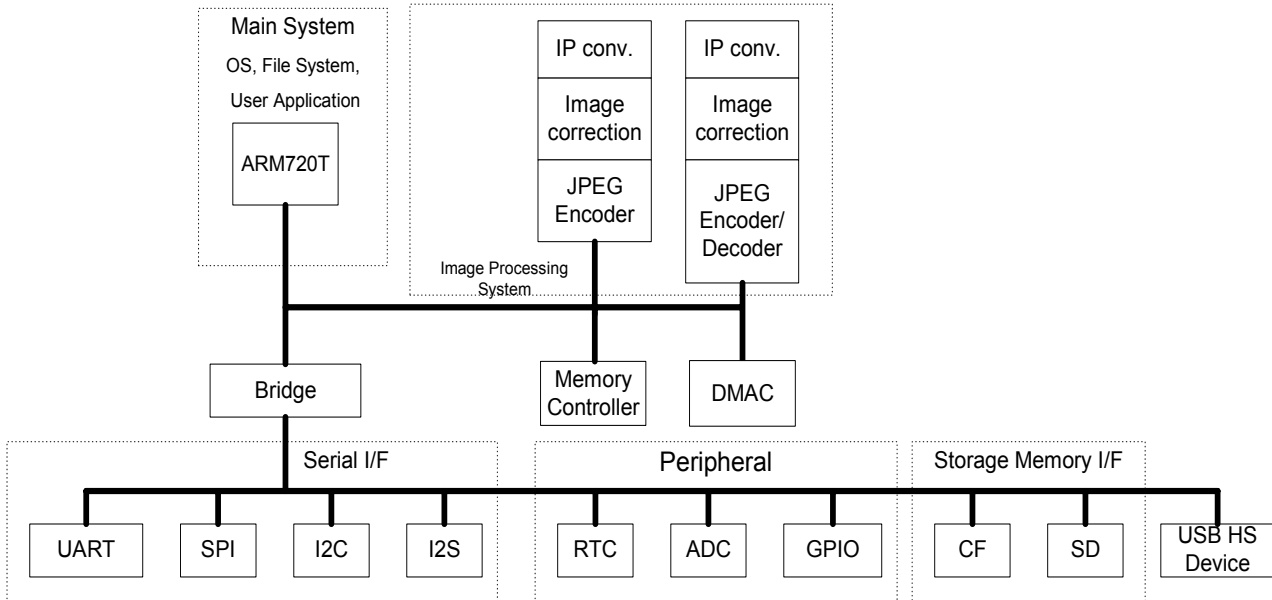

NOTICE:

No part of this material may be reproduced or duplicated in any form or by any means without the written permission of Seiko Epson. Seiko Epson reserves the right to make changes to this material without notice. Seiko Epson does not assume any liability of any kind arising out of any inaccuracies contained in this material or due to its application or use in any product or circuit and, further, there is no representation that this material is applicable to products requiring high level reliability, such as, medical products. Moreover, no license to any intellectual property rights is granted by implication or otherwise, and there is no representation or warranty that anything made in accordance with this material will be free from any patent or copyright infringement of a third party. This material or portions thereof may contain technology or the subject relating to strategic products under the control of the Foreign Exchange and Foreign Trade Law of Japan and may require an export license from the Ministry of Economy, Trade and Industry or other approval from another government agency.



ARM is a registered trademark of ARM.

CompactFlash is a registered trademark of SanDisk.

All other company and product names are trademarks or registered trademarks of the respective companies.

©Seiko Epson Corporation 2008, All rights reserved.

SEIKO EPSON CORPORATION

SEMICONDUCTOR OPERATIONS DIVISION

IC Sales Department

IC International Sales Group

421-8 Hino, Hino-shi, Tokyo 191-8501, JAPAN

Phone: 042-587-5814 FAX: 042-587-5117

■ EPSON Electronic devices Website

http://www.epson.jp/device/semicon_e/